

Profi Liner Multi Steel

Type: SDP 27 eLB3-BS

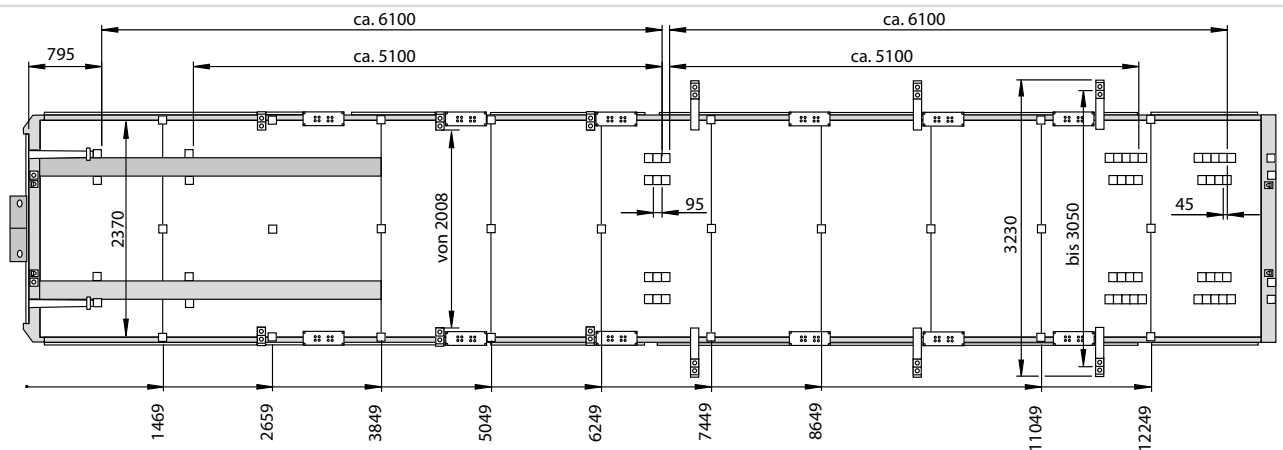

Profi Liner 3 for transportation of steel

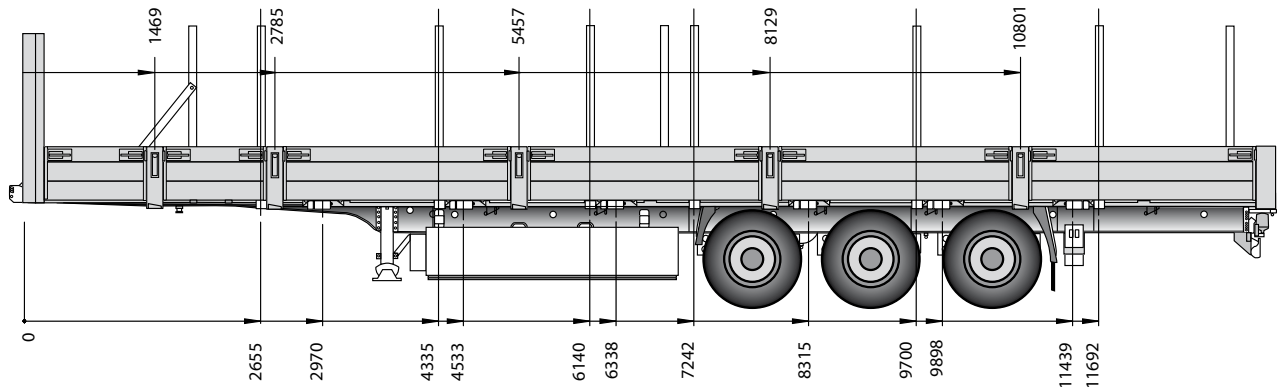

Notice: Stationary load (e.g. transport of prestressed concrete) is not allowed

Technical data:	
Type:	SDP 27 eLB3-BS
King pin load:	12,000 kg
Axle load (technically possible):	27,000 kg
Allowable gross weight (technically possible):	39,000 kg
Tare weight:	approx. 6,800 kg
Payload (technically possible):	approx. 32,200 kg

(Dimensions and weights for standard units)

Axle spread:	1,310 / 1,310 mm
Neck height:	125 mm
5th wheel height:	1,150 mm
Clear length:	13,620 mm
Clear width:	2,480 mm
Turning radius:	2,040 mm

Technical description:	
Multi Lock side rave including load securing positions every 100 mm	
8 pair of reinforced Multi Lock securing points in side rave, each for max. 4 to. drag, (uniformly distributed over total length)	
Designed for transport of reinforcement steel mesh, with overall length 2 x 5 mtr. or 2 x 6 mtr., with stanchion pockets in floor and outer frame, on both sides 6 telescopic stanchion supports, for internal width: 2010, 2120, 2190 mm and 2300 mm - 3050 mm, on both sides 6 mesh tension devices with steel wire roop (or straps); 6 pairs heavy duty lashing rings, integrated into the tension devices	
18 Stanchions with total length 2.150 mm; 2 Stanchions with cross-tie, total length 2.150 mm; 4 supports for straps to strap down the stanchions; 3 pairs Multi lashing rings; stanchion-depot on both sides for 5 stanchions per side	
warning plates for over-width transport, two plates on each side, incl. lighting	
2 mechanically operated landing legs, 2 x 12 tonnes capacity, half round compensating feet	
Low-maintenance axles with air suspension and disc brakes (430 mm); raise/lower valve (1 valve); Rims centre nave	
Tyres: 6 x 385/65 R 22.5, brand: Krone choice	
Without spare wheel carrier	

EC braking system including vehicle stabilising system; low-maintenance automatic; spring-loaded hand brake; 2S/2M EBS system, 2 sensors on each axle with RSS, diagnostics on ISO 7638 socket (EBS)	
24 volts lighting system with 2 x 7-pin socket DIN ISO 1185/3731; front and rear marker lights; with 2 multi-function rear lights acc. to EC incl. rear fog light and reversing lights; 2 large contouring lights with rubber arm; side marker lights in LED; 4 plugs (3-pin) for over-width warning paltes on sides of trailer; 1 rotating flashing beacon	
30 mm thick, phenolic coated plywood floor, cut surfaces fully waterproofed and sealed. Strength acc.to DIN 283; for floor loadings up to 7.000 kg stacker-truck axle load	
Front wall bolted with stable corner posts, height: 2000 mm; lateral restricted through loading; Front wall reinforced with plywood inner skin; Lashing points on the left and on the right;	
6 drop sides each side, 2 x in front approx. 1.200 mm lenght and 4 x approx. 2.540 mm lang; drop sides height: 550 mm; Alloy rear wall, 550 mm high, hinged and removable, tension rod, 1 foldable step; Chains for hinged rear door (two-sided)	
Steel parts shot blasted, with KTL primer and high-quality surface coating (standard painting single-colour); axles incl. wheel hubs painted black; underrun protection and light panel powder coated white for safety reasons; wheels silver with high-quality paint finish; accessories black or galvanized. reflective outline marking according to ECE-R48	

