

Profi Liner 4 in sliding roof design

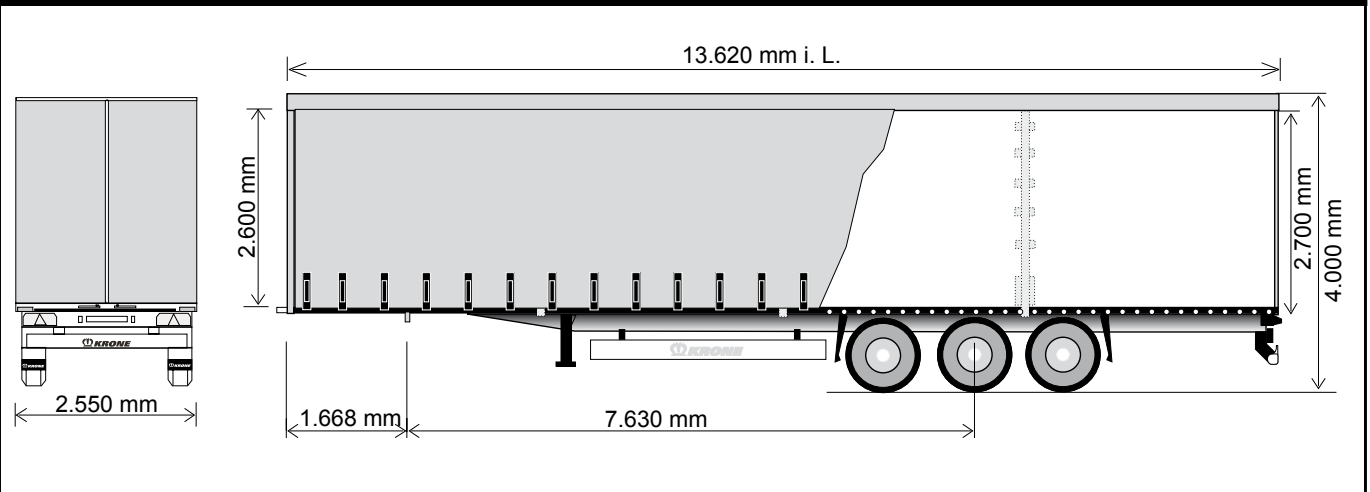

Technical data:

Type:	SDP 27 eLB4-CS
King pin load:	12 000 kg
Axle load (technically possible):	27 000 kg
Allowable gross weight (technically possible):	39 000 kg
Tare weight:	approx. 6 250 kg
Payload (technically possible):	approx. 32 750 kg
Axle spread:	1 310 / 1 310 mm
Neck height:	125 mm
5th wheel height:	1 050 - 1 170 mm
Side access length:	13 620 mm
Side access height:	2 575 - 2 800 mm
Side access width:	2 480 mm
Turning radius:	2 040 mm

(Dimensions and weights for standard units)

Multi Lock side rave as standard:

Award winning Multi Lock side rave including load securing positions every 100 mm. Load securing even diagonally to the driving direction with more than 3000 strapping positions. Cost-effective and with best benefit.



No matter which loads should be transported, with the new Multi Lock- / Multi Blocksystem the loads are perfectly secured.

Technical description:

Multi Lock side rave including load securing positions every 100 mm	Alloy cant rail, continuous, for support of sliding curtain and posts, EDSCHA sliding roof, height 125 mm, Roof also movable to the front and rear, height adjustable from 2,575 to 2,800 mm, 4 sets of wooden planks; diagonal roof spanning
2 mechanically operated landing legs, 2 x 12 tonnes capacity, half round compensating feet	Front wall bolted with solid corner posts; lateral restricted through loading; Front wall reinforced with plywood inner skin; quick release for side curtains on front wall; retainer for curtain cord
Low-maintenance axles with air suspension and disc brakes (430 mm); raise/lower valve (1 valve); Rims centre nave	Steel container rear doors including bolted steel frame, integrated double door looks and concealed door hinges; roof header hinged and movable
Tyres: 6 x 385/65 R 22.5, brand: Krone choice	3 pairs of side posts, symmetrical, with 6 different mounting positions, plank pockets for posts
Wheel covering according to EC-regulations 78/549/EWG ff. and 91/226 EWG, including black mud flaps	Delta shaped rubber profiles at rear; delta steel buffers at rear; load security certificate according EN 12642 Code XL
Without spare wheel carrier	1 PVC curtain with full lengths vertical reinforcements, top with rollers for sliding curtains, bottom with tensioners, curtain tensioner out of stainless steel
EC braking system including vehicle stabilising system; low-maintenance automatic; spring-loaded hand brake; 2S/2M EBS system, 2 sensors on each axle with RSS, diagnostics on ISO 7638 socket (EBS)	Steel parts shot blasted, with KTL primer and high-quality surface coating (standard painting single-colour); axles incl. wheel hubs painted black; underrun protection and light panel powder coated white for safety reasons; wheels silver with high-quality paint finish; reflective outline marking according to ECE-R48
24 volts lighting system with 2 x 7-pin socket DIN ISO 1185/3731; front and rear marker lights; with two multi-function rear lights acc. to EC incl. rear fog light and reversing lights; 2 contouring lights with rubber arm in LED; side marker lights in LED	
30 mm thick, phenolic coated plywood floor, cut surfaces fully waterproofed and sealed. Strength acc.to DIN 283; for floor loadings up to 7 000 kg stacker-truck axle load	

Subject to modifications!
VF/Beu issue 06/2011