

3-axle cooling trailer with ATP/FRC certificate – side and rear view

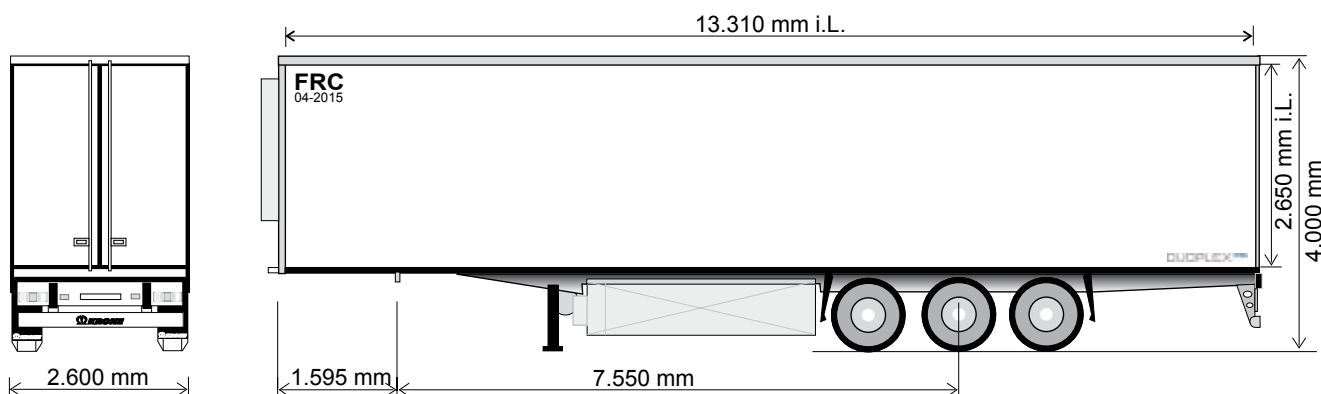

Technical data	
Type:	SDR 27 eL4-S
King Pin load:	12,000 kg
Axle load (technically possible):	27,000 kg
Perm. total weight (technically possible):	39,000 kg
Tare weight (without cooling unit):	approx. 7,530 kg
Tare weight (with cooling unit and tank):	approx. 8,300 kg
Coupling height unloaded:	1,150 mm
Axle spread:	1,310 / 1,310 mm
Internal length:	13,310 mm
Internal width:	2,470 mm
Internal height:	2,650 mm

Technical data	
External length:	13,550 mm
External width:	2,600 mm
Total height unloaded:	4,000 mm
Loading volume:	approx. 87,45 m <sup>3</sup>
Panel thicknesses	
Front wall:	50 mm
Side walls:	60 mm
Roof:	85 mm
Doors:	90 mm
Floor:	125 mm

(Dimensions and weights for standard units)

**Technical description:**

Double T-longitudinal beams and cross members, rear traverse with diagonal reinforcements, without outer frame and beam for self-supporting box, integrated in the body-work, Neck height: 10 mm (8 mm rubbing plate)
Low-maintenance axles with air suspension and disc brakes (430 mm); raise/lower valve (1 valve) incl. auto reset; Rims centre nave
Low-maintenance axles with air suspension and disc brakes (430 mm); raise/lower valve (1 valve) incl. auto reset; Rims centre nave
Tyres: 6 x 385/65 R 22.5, brand: Krone choice
Without spare wheel carrier
Wheel covering according to EC-regulations 78/549/EWG ff. and 91/226 EWG, including black mud flaps; Spray suppression according to EC-regulations
EC braking system including vehicle stabilising system; low-maintenance automatic; spring-loaded hand brake; 2S/2M EBS system, 2 sensors on each axle with RSS, diagnostics on ISO 7638 socket (EBS)
24 volts lighting system with 2 x 7-pin socket DIN ISO 1185/3731; front and rear marker lights; with two multi-function rear lights acc. to EC incl. rear fog light and reversing lights; 2 large contouring lights with rubber arm in LED; side marker lights in LED
Plastic fuel tank, approx. 240 litres (when equipped with cooling unit); closed pallet box for 36 Euro-pallets, 1 PVC tool box
Low-noise alloy floor; floor load capacity tested acc. to CSC/EN 283; reinforced at rear

Self-supporting box Thermal bridge free panel construction, panels on both sides with steel, outer skin; 100 % CFC-free
Roof sandwich panel with steel outer skin, integrated tunnel for temperature control unit and for lighting system, automatic door light switch (at rear doors), 4 LED-flush ceiling lamps, apply to the roof mounted, laterall offset
Front wall sandwich panel including reinforcement and cutaways for installation of cooling unit; shock test according to Swedish norm, 50 mm recess with 4 vertical alloy distance profiles, Front wall with protection wall (4 mm), hinged
Side wall sandwich panels with steel outer skin, exterior painted, interior PVC coated; base tube joined on front and both sides, 300 mm alloy kick strip fully welded to floor
GRP faced container type double rear doors; alloy steel die cast hinges on each door, multiple lipped door sealing system with outside dust protection, one pair of stainless steel door lock rods; 2 door lockings with 1 hand operation
Air duct elastically supported, automatic switch for roof light; ATP- and HACCP Certificate, cooling unit by request for extra charge
Steel parts shot blasted, with KTL System and high-quality surface coating; axles incl. wheel hubs coated black; underrun protection and light supports white for safety reasons, powder-coated; wheels silver with high-quality paint finish; accessories black or galvanized; laminate coating coloured in RAL 9010 white; reflective outline marking according to ECE-R48